



SARbot™ MiniROV System

The SeaBotix Search & Rescue MiniROV system is the world's first rapid response underwater rescue system designed for saving lives.

Underwater remotely-operated vehicles (ROVs) have traditionally been used for the search and recovery of drowning victims, but advancements in medical knowledge increase the chances of reviving drowning victims in up to ninety minutes in some cases. In response, SeaBotix has worked closely with the UK Fire and Rescue Service to develop a portable and safe rescue system.

The SeaBotix SARbot™ allows Rescue Teams to locate and rescue people in demanding conditions regardless of water clarity and without further risk to human life. The system is deployable in less than three minutes. Powerful thrusters enable deep operations in strong currents while the high-resolution imaging sonar helps Operators locate and navigate to victims, even in zero visibility. A high-resolution video camera provides real-time situational awareness at the recovery point where a large Interlocking jaw is used to grasp limbs. The all copper, rugged tether has a 100 kg f (220 pd f) working strength and can easily be used to recover a person in water.

The SeaBotix SARbot™ is the latest version of a proven ROV system currently deployed in critical operations worldwide. The SARbot™ is constructed using our hardened technologies including an extremely intuitive control system, sunlight-readable monitor, ultra-bright white LED lighting, and low-drag Kevlar-reinforced tether.

The SARbot™ is designed to save lives while keeping Rescue Teams out of harm's way.

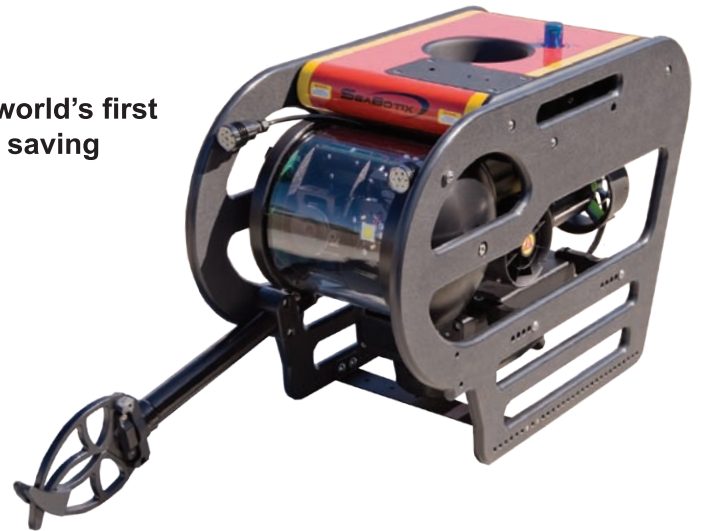

- Rapid setup and deployment < 3 minutes
- 2 person operation
- Fast flow operating capability
- High resolution low light camera
- 150 (500ft) meter excursion and depth capability
- Zero visibility imaging sonar
- Quick release large limb grasping jaw grabber
- Direct sunlight readable monitor

General

Depth Rating:	150m (500ft)
Length:	549mm (21.6in)
Width:	250mm (9.8in)
Height:	368mm (14.5in)
Diagonal:	445mm (17.5in)
Weight in air:	17.4kg (38.4lbs)

Thrusters/Performance

Configuration:	2 forward, 1 vertical, 1 lateral
Motor Type:	Brushless DC direct drive
Speed:	>3 knots (fully equipped)

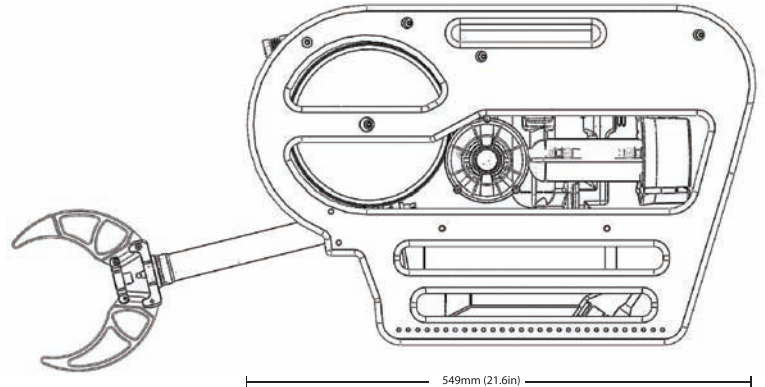

Cameras/Lighting

Camera:	520 line High resolution color
Range of View:	270 Degrees
Focus:	Manual (90mm to infinity)
Lighting:	Internal 700 Lumen LED array Tracks color camera 2 x External 1080 Lumen LED arrays

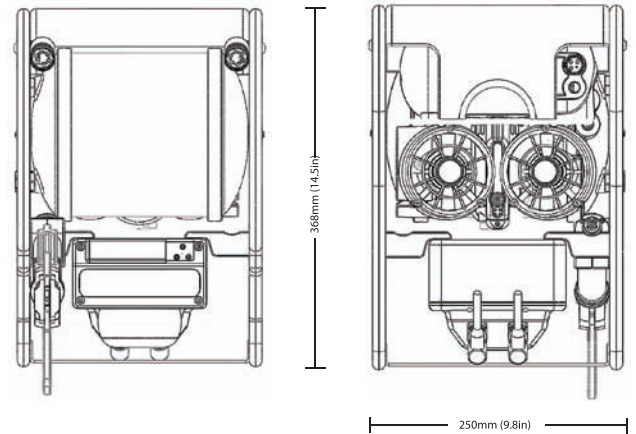

Control System

Configuration:	Rugged case with weatherproof monitor and removable operator control unit
Monitor:	51cm (20") LCD sunlight readable, transreflective
Power Requirement:	1,300 watts, 100-130/200-240 VAC, 50/60hz
Safety:	Isolated input, circuit breaker, LIM, leak monitor Meets & exceeds AODC 035 "Code of Practice for the Safe use of Electricity in Water"
Auto Functions:	Depth, heading, trim
Video Overlay:	Depth, heading, lights, thruster gain, turns counter, camera angle, time, date and user programmable characters
Video Enhancement:	LYYN video enhancer
GPS:	Built in GPS receiver

Tether

Diameter:	8mm (0.3in) nominal
Length:	150m (500ft) standard
Working Load:	100 kg f (220 pd f)
Breaking Strength:	700 kg f (1,543 pd f)
Core:	Copper (no fiber)
Buoyancy:	Neutral in fresh, slightly positive in seawater
Reel:	Heavy duty with slip ring

Grabber

Attachment:	Quick release large (limb) grasping jaws
Opening Size:	119mm (4.7in)

Sonar

Manufacturer:	Tritech International
Model:	Gemini 720i
Range of View:	120° horizontal

Options

Tracking:	Tritech Micron Nav USBL positioning system
Grabber Attachments:	Three jaw, cutting tool, small interlocking jaws

